

ELECTRONIC  
MUSICAL INSTRUMENT &  
CALCULATOR

INSTRUMENTO  
MUSICAL ELECTRONICO Y  
CALCULADORA

**CASIO**

**VL-TONE<sub>VL-1</sub>**

---

**OPERATION MANUAL**

---

**MANUAL DE OPERACION**

---

---

## CONTENTS

---

1. Casio VL-TONE Features . . . . .	2
2. Points Of Caution . . . . .	4
3. Power Supply . . . . .	5
4. Nomenclature And Function Of Each Part . . . . .	8
5. Manual Play Function . . . . .	11
6. Auto Rhythm Function . . . . .	12
7. One Key Play Function . . . . .	14
8. Auto Play Function . . . . .	18
9. ADSR Function . . . . .	21
10. Melody Demonstration . . . . .	24
11. Connecting With Other Equipment . . . . .	25
12. Calculator Function . . . . .	26
13. Specifications . . . . .	29

---

## 1. Casio VL-TONE Features

---

- **One Key Play Function** — You can play by just pressing one key.

You can store notes in the memory and the notes will be individually played back in sequence each time you press the key to create a melody. Anyone can enjoy playing immediately even though they may never have played before.

- **Auto Play Function** — Your playing will be played automatically.

Your favorite selected melody can be stored entirely and played back automatically. There is a repeat function that will replay the melody four times.

- **Manual Play Function** — You can enjoy playing right away.

There are a total of 29 keys and nearly two and a half octaves. Half tones are included so that you can play any tune. This function makes the instrument easy to play.

- **Auto Rhythm Function** — The sharp rhythm background makes your music sound better.

Swing, Bossa Nova, Rock and other rhythms up to 10 different in all are possible. Tempo and balance can be freely adjusted over a wide range. This auto rhythm function makes your music more emotional.

- **ADSR Function** — You can create your own sounds and make a mini-synthesizer.

With this function sound wave elements like, attack, decay, vibrato, etc., a total of 8 different data, can be applied to create

sound variations. Up to 80 million combinations are possible. You can create your own original sounds.

- **5 Preset Sounds — You can select any one of the 5 preset sounds to go with the melody.**

Piano, fantasy, violin, flute and guitar, 5 different lovely sounds are preset. Additionally, by using the octave shift, the music range can be shifted to 3 different levels.

- **Melody Demonstration — The instrumental sound and rhythm will be varied step by step.**

“German Folk Song” can be played automatically with rhythm included. The instrumental sound and rhythm changes to make very enjoyable music.

- **Calculator Function — You can change at once from melody keys to calculator keys.**

When you set the selector to “CAL” the keyboard keys become

calculator keys and you can calculate up to 8 digits — add, subtract, multiply, divide, 4 constants, square root, percentage and memory calculation.

---

## 2. Points Of Caution

---

- This instrument is constructed with very precise electronic parts. Usage or storage under extreme temperature conditions, or strong shock must be avoided. Under very low temperature conditions, the response speed may be slow or the instrument may fail to operate. Also, under very high temperature conditions, the battery life will be shortened. Do not store or place near heating systems, in direct sunlight, inside a hot car or on a window ledge.
- The instrument is constructed to protect against dust and humidity but is not waterproof. Do not use near splashing water or under high humidity conditions.
- Do not attempt to take the instrument apart because the system and functions will be damaged. Avoid throwing used

batteries into fire.

\* If batteries go bad take them out at once and replace them to avoid damage to the instrument.

- To clean the instrument, use a soft, dry cloth or slightly damp cloth with neutral detergent to wipe it off. Never use thinner, benzene type solvents or alcohol for cleaning.
- When using as a calculator be sure to check that the key depressed and the number indicated in the display are in agreement.
- As a magnet is built into the speaker keep watches, credit cards, etc. clear of the unit.

---

### 3. Power Supply

---

This instrument has a two-way power system and may be operated using battery or AC power.

#### Battery Use

- Use 4 AA size dry batteries.
- Battery life may vary depending on battery type and use conditions.
  - Music use (PLAY/REC mode) — 12 hours continuous.
  - Calculator use (CAL mode) — 4,000 hours continuous.
- \* Above battery life is based on type UM-3.
- When the batteries are worn out the sounds and notes may become unstable or noise may be produced. In this case the batteries should be replaced with new ones.

- \* To replace batteries, slide open the battery compartment lid on the bottom of the instrument and insert new batteries making sure that the  $\oplus/\ominus$  poles are properly aligned. Always replace all 4 batteries to insure longer life.

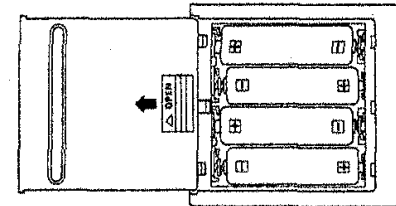

- \* After replacing batteries, set the mode selector to "CAL" and press the P button on the bottom of the instrument with a pointed object.  
**CAUTION** — To prevent corrosion or damage, remove the batteries when not using the instrument for long periods of time.

### AC Use

- AC power can be used by connecting an optional AC adaptor.
- \* Use only the adaptor with the same voltage rating (100, 117, 220 or 240V) as your power supply to prevent component damage.
- The battery power will be automatically disconnected when using the AC adaptor and will reduce battery consumption for better economy.

**CAUTION – WHERE USED FROM THE MAINS THIS UNIT MUST ONLY BE USED WITH A CASIO MAINS ADAPTOR. THIS IS DUE TO THE RISK OF DAMAGE TO THE UNIT SHOULD IT BE USED WITH A MAINS ADAPTOR OTHER THAN CASIO MAINS ADAPTOR.**

**NOTE –**When switching on the power with an AC adaptor in use, press the P button before playing the instrument with the mode selector at “CAL”.

If you use the adaptor for long periods of time it may heat up but this is a normal condition. The adaptor should be disconnected from the wall outlet when not in use.

The contents of the memory (accumulated total of memory calculation), stored melody or the preset data of ADSR function will be cleared by replacing batteries.

### Auto-Power-Off (A.P.O.)

For power economy the unit provides auto-power-off (A.P.O.) function. If the unit is left with the mode selector turned on, the A.P.O. function automatically turns off the power in approximately 6 minutes.

Though the display disappears, the contents of the memory (accumulated total of the memory calculations or the preset data of the ADSR and/or the stored melody) are protected. Power is resumed either by pressing  key or by turning off and on.



## 4. Nomenclature And Function Of Each Part

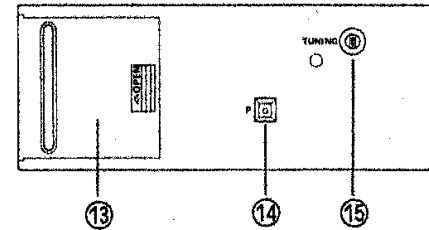
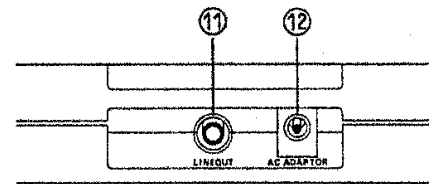
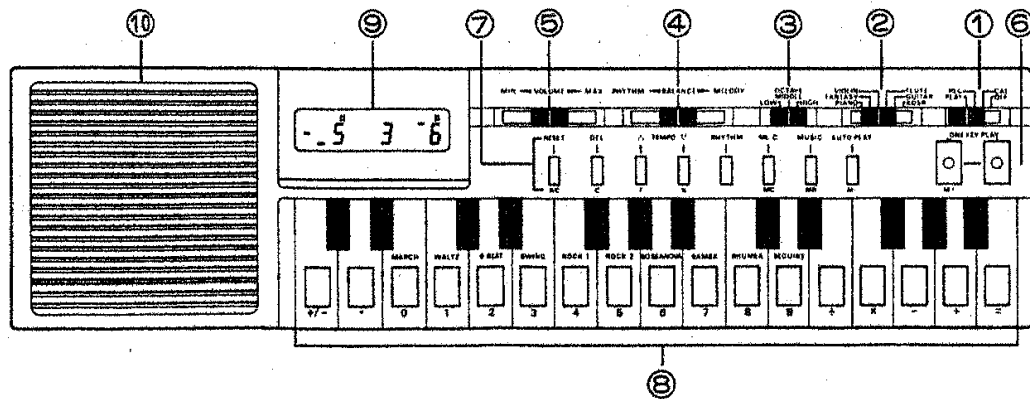

### Nomenclature

- ① Mode Selector
- ② Sound Selector
- ③ Octave Shift Switch
- ④ Balance Control
- ⑤ Volume Control
- ⑥ One Key Play Keys
- ⑦ Function Keys
- ⑧ Keyboard Keys
- ⑨ Display
- ⑩ Speaker
- ⑪ Line Out Jack
- ⑫ AC Power Terminal
- ⑬ Battery Compartment Lid
- ⑭ P Button
- ⑮ Pitch Control

## ● Individual Functions

### ① Mode Selector

Functions as Power On/Off Switch.

- OFF – Power Off
- CAL – To calculate or to preset the ADSR data.
- REC – To store notes or melody
- PLAY – To use one key play, auto play or manual play

### ② Sound Selector

To select piano, fantasy, violin, flute or guitar sound or to use the ADSR function

### ③ Octave Shift Switch

Changes the keyboard to three different musical ranges.

### ④ Balance Control

Use to blend the melody and rhythm volume. Slide left to increase the rhythm volume or right to increase the melody

volume. Rhythm and melody volumes will be equal when control is in the center.

### ⑤ Volume Control

Controls the volume of all sounds. Volume will be increased when the control is moved to the right.

### ⑥ One Key Play Keys

- You can play by using only one key. Each time this key is pushed the notes stored in the memory will come out in the sequence in which they were stored in the memory. Either of the two one key play keys may be used to provide the same effect.
- When the mode selector is in the CAL position the left key will be the memory plus (M+) key and the value indicated in the display will be stored in the memory.

### ⑦ Function Keys

When the mode selector is on either **PLAY** or **REC**, the functions indicated above the various keys are used. When the mode selector is on **CAL**, the functions indicated below the various keys are used.

\* Functions of the various keys will be explained in the following paragraphs.

### ⑧ Keyboard Keys

Used to play notes or melodies when the mode selector is in the **PLAY** position or store them in the memory when the mode selector is in the **REC** position. Keyboard keys with rhythm names above them also function as rhythm selectors when the mode selector is in the **PLAY** or **REC** position. Also white keys are used as calculator keys when the mode selector is in the **CAL** position.

### ⑨ Display

Displays notes and tempos. Displays entries and answers when calculating.

### ⑩ Speaker

### ⑪ Line Out (output) Jack

Powerful volume can be enjoyed by connecting external audio equipment and speakers. Direct recording can be accomplished by connecting this terminal to a tape recorder input terminal. (Details on page 25.)

### ⑫ AC Power Terminal

Connects the AC adaptor. (Details on page 6.)

### ⑬ Battery Compartment Lid

### ⑭ "P" Button

Press this button to operate after replacing batteries.

### ⑮ Pitch Control

All keyboard keys can be tuned up or down by as much as a half tone. This makes it easy to tune with other instruments in an ensemble.

\* Be sure to use a standard plastic-grip screwdriver.

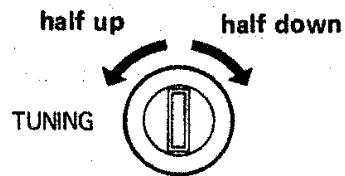

## 5. Manual Play Function

First, let's produce a sound.

### 1. Activating Power

\* Set the mode selector to PLAY.



### 2. Selecting A Sound

\* Switch Sound selector to any position except ADSR.



### 3. Adjusting Volume

\* Adjust the volume control as shown in the diagram.



#### 4. Well Let's Play

\* When you press a key on the keyboard the sound you selected will be produced. Play your favorite melody.

- Enjoy your playing by using the sound selector to change the sound or the octave shift switch to change the note range.

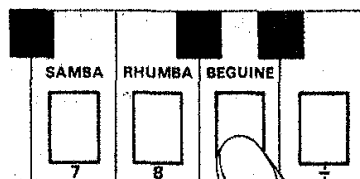

#### 6. Auto Rhythm Function

Let's have some rhythm.

This function automatically generates sharp rhythms such as march, swing, samba and others. There are 10 different rhythms in all to make your music more enjoyable.

- Selecting A Rhythm

1. Set the mode selector to PLAY.



2. Press the <sup>RHYTHM</sup> key.



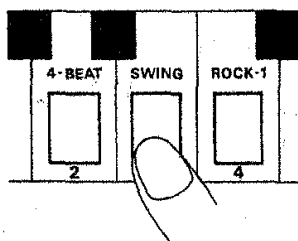

3. Press your favorite rhythm key on the keyboard.

- The rhythm will begin as soon as you press the key.
- \* To stop the rhythm, press the  key.



● **Adjusting The Tempo (Speed)**

- Use the tempo keys to make adjustments. Press the  key to go faster. Press the  key to go slower.
- The tempo can be adjusted from -9 to +9 and will be indicated in the display.

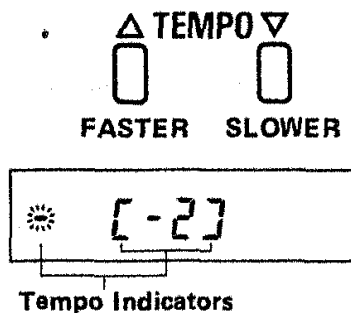



● **Adjusting The Volume Balance**

The balance control balances the rhythm and melody volume.

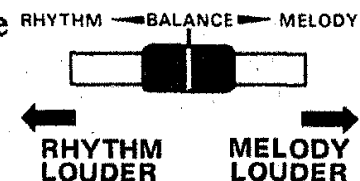
- \* To control the overall volume of all sounds, use the volume control.



**NOTE** — If you switch the mode selector or press the ,  or  key while the rhythm is playing the rhythm will stop.

## 7. One Key Play Function



### • How To Play With One Key

#### Note Storage

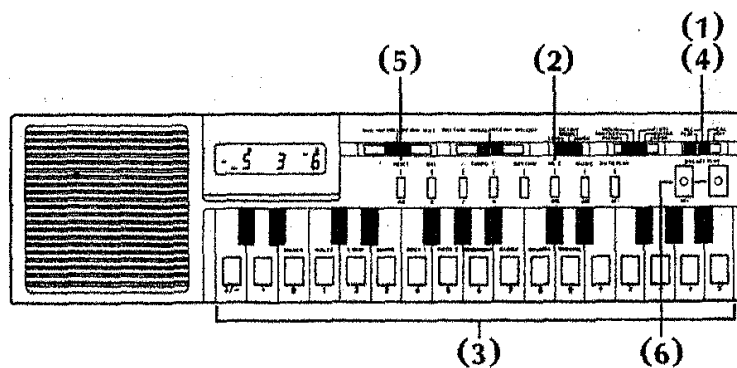
- (1) Set the mode selector to REC.
- (2) Press the melody clear key (  ) to clear the previous stored melody.
- (3) Press a keyboard key and the note will be stored in the memory.



#### One Key Play

- (4) Set the mode selector to PLAY.
- (5) Push the  key.
- (6) When you press either of the  keys the notes stored in the memory will be played in the sequence in which you stored them. Select your favorite tempo.

\* Enjoy playing by changing rhythms and octaves.

**EXAMPLE:**

**"When The Saints Go Marchin' In."**  
(American folk song)

\* Enter the following notes (by number or by the musical score):

\* If you make a mistake press the  key to remove the mistaken note and then press the correct key and continue.

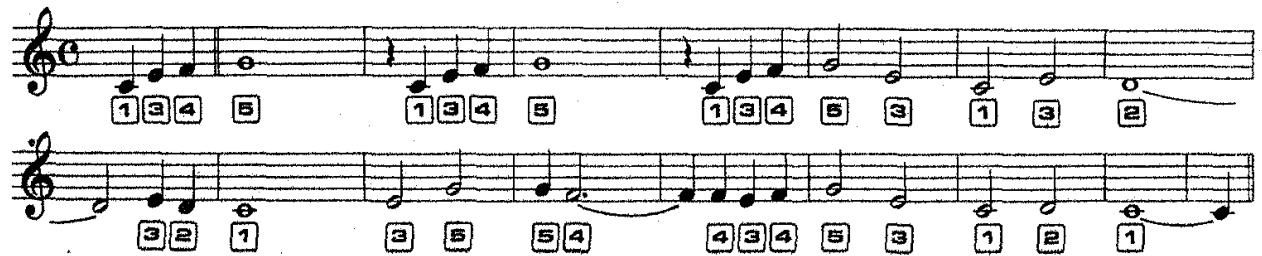

The image shows a musical score for the song "When The Saints Go Marchin' In." It consists of two staves of music in treble clef, 2/4 time. The first staff contains the first line of music, and the second staff contains the second line. Below each staff are fingerings indicated by numbers in boxes. The first staff has fingerings: 1 3 4 5, 1 3 4 5, 1 3 4 5 3, 1 3 2. The second staff has fingerings: 3 2 1, 3 5 5 4, 4 3 4 5 3, 1 2 1.



● **How To Read The Display**

(When performing function #3, under Note Storage on page 14)

The last three notes pressed will be displayed in the display with the last note pressed on the right. This way you can make sure which notes are being stored. The illustration shows the relationship between the keyboard key and the display.

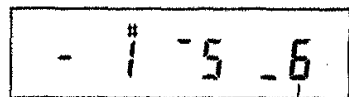

NOTE LAST PRESSED

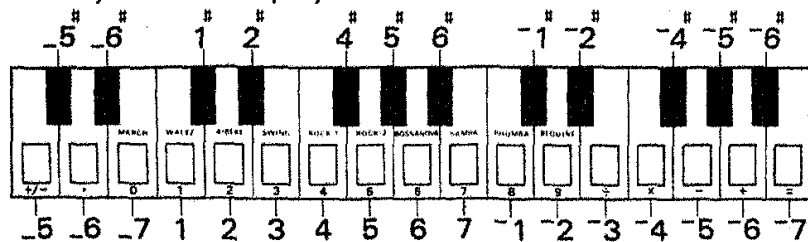

● **How To Make Corrections**

**If You Make A Mistake While Storing Notes**

Press the delete key (DEL) and then press the correct key on the keyboard.

**If You Want to Locate And Correct A Wrong Note**

Slowly use one key play until you find the wrong note. Press the DEL key and then press the correct key on the keyboard.

\* When you make a correction a "beep" correction tone will be heard.

● Up to 100 notes can be stored in the memory. If you try to store more than 100 notes, overflow occurs and dots appear on the display as shown. No more entry can be made.

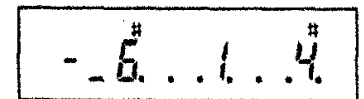

### More Enjoyable One Key Play

#### 1. Repeat Play

After the last note is played when using One Key Play repeat play can be accomplished from the beginning by pressing the One Key Play Key at that time.

#### 2. Medley Play

If the total of notes is within 100, a medley can be played by storing multiple tunes and using One Key Play.

#### 3. Additional Memory

If the memory still has capacity, an additional tune can be stored in the memory without erasing the tune that is already stored.

##### (How To Use)

Use One Key Play in the REC mode. After the last note is played use the keyboard keys to store the additional tune.

#### 4. Memory Break In

New notes can be inserted (break in) in between the notes already stored in the memory to remake a brand new melody.

##### (How To Use)

Use One Key Play in the REC mode. When you reach the position where you want to break in, press the keyboard keys to store notes in the memory. At this time a "beep" tone will be heard and the notes can be stored in the memory.



• How To Use Auto Play Method #2.

**Melody Storage**

- (1) Set the mode selector to REC.
- (2) Press the  $\text{M/C}$  key.
- (3) Play a melody on the keyboard.
- (4) After playing press the  $\text{RESET}$  key.

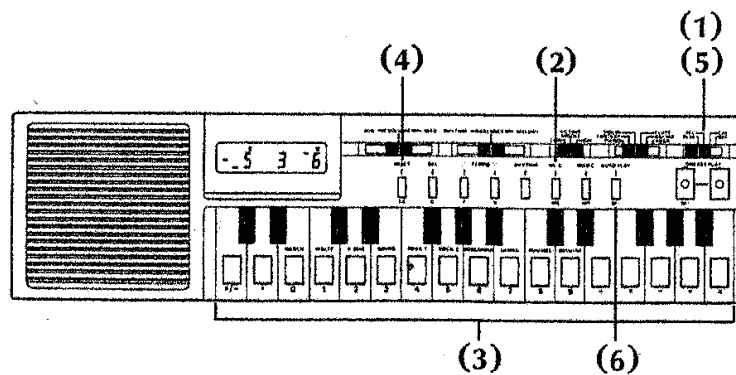

**Auto Play**

- (5) Set the mode selector to PLAY.
- (6) When you press the  $\text{AUTO PLAY}$  key the entire melody will be played back automatically.

- **Sound And Octave Switching**

The sound selection or octave shift can be changed even during auto play.

- **Tempo Adjustment**

You can adjust the tempo even during auto play by simply pressing the tempo keys.

- **Auto Play Reset and Pause**

**Reset** — If you press the <sup>RESET</sup> key during auto play the playing will stop. When you want to listen again press the <sup>AUTO PLAY</sup> key and the playing will start again from the beginning.

**Pause** — If you press the <sup>AUTO PLAY</sup> key during auto play the playing will pause. If you press it once more the playing will resume from where it stopped.

### For More Enjoyable Auto Play

- **How To Add Rhythm Accompaniment To The Auto Play**

1. Store the melody in time with the beat of the rhythm.
  - \* You must start the rhythm before storing the melody (before Step 5 of Auto Play Method #1 or before Step 3 of Auto Play Method #2).
2. Start the rhythm before beginning Auto Play. Press the <sup>AUTO PLAY</sup> key on the beat with the rhythm.
  - \* Please make the rhythm for 1 and 2 above the same. If you press the <sup>TEMPO</sup> key during Auto Play the speed of both the melody and the rhythm will be changed.

## 9. ADSR Function

With this function you can create your own original sounds.

### • How the sound variations are formed.

Generally, a tone (character of a sound) is determined by pitch, loudness (strength) and timbre (tone color). Also in addition to the three elements mentioned above, there is another important factor for determination of a tone; so called "envelope" (the characteristic of the attack and decay of a sound). In short, the change in the loudness (amplitude) with the passage of time (duration). For instance, a sound that slowly builds in loudness such as that of a violin. Another example would be a sound such as that of a guitar where the loudness peaks momentarily when you pick the string and

then reduces quickly. These and many other sound wave variations are possible. The illustration shows an example of the envelope of a piano. The graph shows time (duration) horizontally and amplitude vertically. This is called an "envelope curve". The ADSR function affects 5 elements (Attack, Decay, Sustain level, Sustain time, Release time) in determining the envelope curve and creates many sound wave variations.

• ADSR is an acronym for the 5 elements.

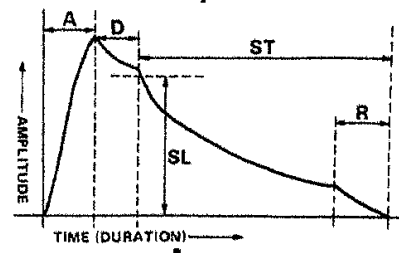

**A : Attack time**  
**D : Decay time**  
**SL : Sustain level**  
**ST : Sustain time**  
**R : Release time**

### How To Set And Use

#### 1. Let's form an 8 digit number to create a sound.

In the following paragraphs the numbers 0 to 9 will be used to determine the sound to be created. 8 numbers must be set in sequence.

a. **Sound Waves** — The following fundamental sound wave variations are available.

0 = Piano	4 = Guitar 1	8 = Electro-Sound 2
1 = Fantasy	5 = Guitar 2	9 = Electro-Sound 3
2 = Violin	6 = English horn	
3 = Flute	7 = Electro-Sound 1	

\* For the items b through f on the right, the greater the number value (0 — 9) the greater the effect on the values illustrated on the graph.

- b. Attack Time
- c. Decay Time
- d. Sustain Level
- e. Sustain Time
- f. Release Time

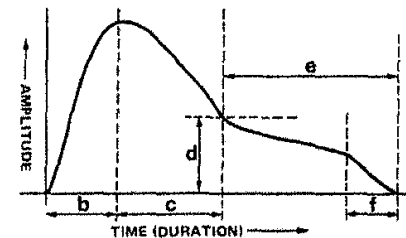

### REFERENCES

- b — A small value of b creates a fast rise time making a sharp sound.
- c, d and e — A large value of c, d and e creates a sound of long duration such as that of a flute or organ. Smaller numbers create sounds of shorter duration such as that of a guitar or koto.
- f — A large value of f causes an echo effect even after you release the key.

\* For the next 2 items a greater value creates a greater effect. A "0" means no effect.

**g – Vibrato** – The pitch will vary at a high rate.

**h – Tremolo** – The volume will vary at a high rate.

**EXAMPLE: "61079130"**

This series of numbers would create the sound wave variations of English horn. The sound wave variations are shown on the graph.

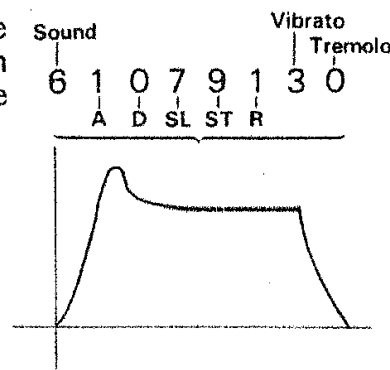

**2. How To Store 8 Digits**

The 8-digit number determined in Paragraph 1 (page 22) can be stored in the memory as follows:

- (1) Set the mode selector to CAL.
- (2) Set the sound selector to ADSR.
- (3) Press the  $\square$  key.
- (4) Press 8 numbers in sequence as shown in Paragraph 1.

**CAUTION:** If the first number is a "0" that number will be ignored.

**EXAMPLE:** "02357806" = "2357806"

"00872850" = "872850"

- (5) Press the  $\square$  key.
- (6) Set the mode selector to PLAY or REC.



Now you can enjoy one key play, auto play or manual play with the ADSR sound.

#### Some examples of ADSR compositions

Violin:	2 3 0 9 9 1 3 0
Piano:	0 0 4 5 3 2 0 0
Synthe-sounds:	7 0 0 9 9 9 2 4
Flute:	3 3 0 9 9 1 3 0
English horn:	6 1 0 7 9 1 3 0

## 10. Melody Demonstration

If you set the mode selector to PLAY or REC and then press the <sup>MUSIC</sup> key the "German Folk Song" will be played automatically. The sounds and rhythms vary during the playing to cause a very pleasing demonstration.

- A Standard tempo is set at (4). You can change the tempo freely while playing by simply pressing the <sup>TEMPO</sup> keys.
- The melody will be repeated 4 times and then will stop. If you want to stop it during play simple press the <sup>MUSIC</sup> or <sup>RESET</sup> key.

## 11. Connecting With Other Equipment

Before connecting the unit please read the operation manual of the equipment to be connected.

- \* The VL-TONE is provided with a LINE OUT (output) jack which allows connection of an external equipment (such as stereo amp., radio cassette recorder or tape-recorder) for more dynamic performance or for direct recording.
- \* *LINE OUT jack of the VL-TONE is made to the mini-plug specifications.*

### CONNECTION DIAGRAM

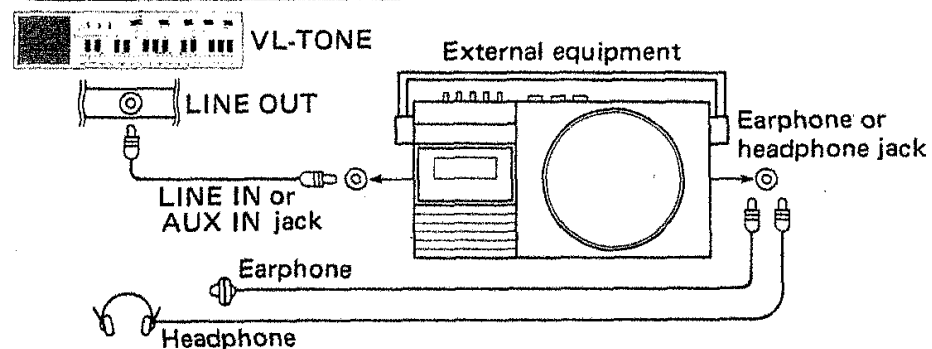

- \* When using an external amplifier is connected, set the volume control to its minimum then increase it gradually to the desired level.
- \* When an external amplifier is connected, the volume level can be controlled freely by the volume control on the VL-TONE.

---

## 12. Calculator Function

---

When you set the mode selector to CAL the keyboard keys and function keys become calculator keys. The numbers and marks shown below the keys indicate their functions.

### How To Calculate

- Set the mode selector to CAL. Press the  $\frac{\square}{\square}$  key. Make sure that the display shows "0".  
Now you can begin to calculate.
- In the following cases an "E" will appear on the display to indicate an error has been made. In this case no further calculations can be made.
  1. A maximum of 8 digits can be used. If you try to insert a number with more than 8 digits (i.e. a number greater than

99,999,999) a period mark will appear in the display ("."). The period mark indicates that the true decimal position is 8 digits to the right.

2. When you exceed 8 digits in the memory. In this case the memory will retain the first 8 digits that were input.
  - \* After making an error if you want to calculate press the  $\frac{\square}{\square}$  key. If you want to begin a complete new calculation press the  $\frac{\square}{\square}$  key.
- If the wrong number key has been pressed press the  $\frac{\square}{\square}$  key then press the correct number key. If a mistake is made when pressing "+", "-", "x" or "÷" keys just press the correct key and continue.

## CALCULATION EXAMPLES

EXAMPLE	OPERATION	READ-OUT
---------	-----------	----------

Basic calculations

$741 - 258 + 963 = 1446$	1446.
$741 \text{ [ ] } 258 \text{ [ ] } 963 \text{ [ ] }$	

$(-45.6) \times 89 \div 7 + 12.3 = -567.47142$	-567.47142
$45 \text{ [ ] } 6 \text{ [ ] } 89 \text{ [ ] } 7 \text{ [ ] } 12 \text{ [ ] } 3 \text{ [ ] }$	

Constant calculations \* When a number is set as a constant, the " [K] " sign appears on the display.

$3 + 1.2 = 4.2$	[K] 4.2
$1 \text{ [ ] } 2 \text{ [ ] } 3 \text{ [ ] }$	
$6 + 1.2 = 7.2$	[K] 7.2
$6 \text{ [ ] }$	

$2.3 \times 12 = 27.6$

$12 \text{ [ ] } 2 \text{ [ ] } 3 \text{ [ ] }$

[K] 27.6
[K] 54.

$4.5 \times 12 = 54$

$4 \text{ [ ] } 5 \text{ [ ] }$

$2.5^2 = 6.25$

$2 \text{ [ ] } 5 \text{ [ ] } \text{ [ ] } \text{ [ ] }$

[K] 6.25
[K] 15.625

$2.5^3 = 15.625$

$\text{ [ ] }$

$2.5^4 = 39.0625$

$\text{ [ ] }$

[K] 39.0625
-------------

Square roots

$\sqrt{2} \times \sqrt{3} + \sqrt{5} = 4.6855575$

$2 \text{ [ ] } \text{ [ ] } 3 \text{ [ ] } \text{ [ ] } 5 \text{ [ ] } \text{ [ ] }$

4.6855575
-----------

### Memory calculations

\* Be sure to press the memory clear key (MC) to clear the previous stored number.

When a number is stored in the memory, the "M" sign appears on the display.

53+6= 59	MC 53 + 6 M+	MJ 59.
23-8= 15	23 - 8 M+	MJ 15.
56×2=112	56 × 2 M+	MJ 112.
+ ) 99÷4= 24.75	99 ÷ 4 M+	MJ 24.75
210.75	MR	MJ 210.75
7+7-7+(2×3)+(2×3) =19	MC 7 M+ M+ M- 2 × 3 M+ M+ MR	MJ 19.

### Percentage calculations

12% of 1500      1500 × 12 %      MJ 180.

Percentage of 660 against 880      660 ÷ 880 %      MJ 75.

15% add-on of 2500      2500 × 15 % +      MJ 2875.

25% discount of 3500      3500 × 25 % -      MJ 2625.

#### Mark-up

What will the selling price and profit be when the purchasing price of an item is \$480 and the profit rate to the selling price is 25%?

480 × 25 %      MJ 640.

Selling price: \$640

(Subsequently) -      MJ 160.

Profit: \$160

**Mark-down**

What will the selling price and loss be when intending to sell a \$130 item with 4% loss rate at a bargain sales price?

130  $\div$  4  $\%$   $\%$  125.

Selling price: \$125.

(Subsequently)  $\ominus$  -5.

Loss: \$5

**Increase/decrease**

If you made \$80 last week and \$100 this week, what is the percent increase?

100  $\ominus$  80  $\%$  25.

(%)

**CAUTION:** The memory function used for the calculator is the same as that used for ADSR. If you use the memory when calculating, the ADSR information in the memory will be erased.

---

### 13. Specifications

---

**Type – VL-1**

● **Music Section**

**Keyboard:** 29 keys (monophonic). Approx. 2.5 octaves (relative pitch).

**Preset sounds:** 5 (piano, fantasy, violin, flute and guitar)

**ADSR function:** Variable sound creations.

**Built-in rhythms:** 10 (march, waltz, 4-beat, swing, rock 1, rock 2, bossa nova, samba, rhumba and beguine)

**Built-in melody:** "German folk song" with melody accompaniment

**Number of notes that can be stored in memory:** 100

**Pitch control:**  $\pm 1/2$  tone ( $\pm 100$  cents)

**Others:** Volume control, balance control, tempo control, octave shift (3 levels).

Speaker: 6cm (2-3/8") dia. x 1 (output 300mW)  
Output terminal: Output voltage 0.5V rms.

● **Calculator Section**

Abilities: 4 basic calculations (+/-/x/÷), square root, percentage, memory, 4 constants and other mixed calculations.

Number of digits: 8 digits

Decimal system: Full floating

Overflow check system: The number prior to the overflow will appear with the letter "E" in the display and calculations will stop.

● **Common Section**

Main component: VLSI

Display: Liquid crystal display.

Display functions: Calculator display, note display and tempo display

Power supply: AC/DC 2-way power

AC: 100, 117, 220 or 240V, 50/60Hz, with an applicable AC adaptor.

DC: 4 AA size batteries

Power consumption: 0.6W maximum

Battery Life: When used for music with mode selector at PLAY/REC . . . \*Approximately 12 hours.

When used for calculator with mode selector at CAL. . . \*Approximately 4,000 hours.

*\*Continuous use with UM-3 type batteries*

Ambient temperature range: 0°C – 40°C (32°F – 104°F)

Dimensions: 30mmH X 300mmW X 75mmD (1-1/8"H X 11-3/4"W X 3"D)

Weight: 438g (15.4 oz) (including batteries)

---

**GUIDELINES LAID DOWN BY FCC RULES FOR USE OF THE UNIT IN THE U.S.A. (not applicable to other areas).**

This equipment generates and uses radio frequency energy and if not installed and used properly, that is, in strict accordance with the manufacturer's instructions, may cause interference to radio and television reception. It has been type tested and found to comply with the limits for a Class B computing device in accordance with the specifications in Subpart J or Part 15 of FCC Rules, which are designed to provide reasonable protection against such interference in a residential installation. However, there is no guarantee that interference will not occur in a particular installation. If this equipment does cause interference to radio or television reception, which can be determined by turning the equipment off and on, the user is encouraged to try to correct the interference by one or more of the following measures:

- ..... reorient the receiving antenna
- ..... relocate the computer with respect to the receiver
- ..... move the computer away from the receiver
- ..... plug the computer into a different outlet so that computer and receiver are on different branch circuits.

If necessary, the user should consult the dealer or an experienced radio/television technician for additional suggestions. The user may find the following booklet prepared by the Federal Communications Commission helpful: "How to Identify and Resolve Radio-TV Interference Problems". This booklet is available from the US Government Printing Office, Washington, D.C., 20402, Stock No. 004-000-00345-4.



**CASIO®**

041B SA (英) (西) Printed in Japan